

Fides



sound meets design

trumpets  
cornets  
flugelhorns  
trombones  
corno da caccia

Matthias  
beck  
Masterpiece

# Table of Contents

## Trumpets

Bb-Trumpets Périnet	
Bb-Trumpets overview	page 7
Pocket-Trumpets	page 21
Bb-Trumpets Rotary	
Bb-Trumpets overview	page 36
C-Trumpets Périnet	
C-Trumpets overview	page 16
C-Trumpets Rotary	
C-Trumpets overview	page 36
High Trumpets Périnet	
D/Eb/E-Trumpet	page 25
Piccolo Trumpets	page 22
High Trumpet Rotary	
Piccolo Trumpet Rotary	
Beck Masterpiece Exsultare	page 40

## Bb-Cornets

Cornets	page 20
---------	---------

## Flugelhorns Périnet

Bb-Flugelhorns Périnet	
Flugelhorns overview	page 26
C-Flugelhorn Périnet	
C-Flugelhorn Masterpiece	page 32

## High Horn (for trumpet players)

Beck Corno da caccia	page 41
----------------------	---------

## Trombones

Trombones	page 33
-----------	---------

### IMAGES AND INSTRUMENTS:

*Through the continuous development of our product range, in some circumstances the images may not match precisely the models shown.*

*While great care has been taken in compiling this information, we are not responsible for any technical errors or possible printing errors.*

*Dettingen, March 2017*

# sound meets design



## LOOKING FORWARD TO THE FUTURE TOGETHER

In the Autumn of 2004, Francisco Montesinos Fides and Matthias Beck founded the Spanish company, MUSIC DEVELOPMENT S.L.

The idea was to develop a new product line featuring a range of our own instruments. The foundation and philosophy was to offer our products to a wider international market and to create a new brand that reflects the warmth of our aesthetic values.

## BIRTHPLACE SCHWÄBISCHE ALB

This new venture was founded in the Schwäbische Alb (the Swabian Alps, a low mountain range in southwest Germany).

The instruments Fides and Beck are developed by technicians and craftsmen in the workshop of Matthias Beck in Dettingen at the foot of Schwäbische Alb.



*Matthias Beck,  
Professional Trumpeter,  
Instrument Maker and Designer*

Francisco Montesinos Fides, born in Valencia, is responsible for international marketing.

## OUR ACHIEVEMENTS

Ever since our inception, we have continued to gain international recognition from musicians and the music industry.

Our models range from high quality instruments for beginners to those at the height of their profession either as soloists or members of an orchestra.

Fides is a Latin word meaning Faith, Trust and Loyalty, and with that base we orient our work to look at the future.



*Francisco Montesinos Fides,  
Managing Director  
Music Development S.L*



# Design, the total solution is our passion





*Beck*  
*Masterpiece*



arts  
and  
craft



# Rubén Simeó

## *Rubén Simeó,*

*Ruben is a young Spanish internationally recognized trumpet soloist.*

*In 2008, in recognition of his brilliant concert career, he was awarded the European Prize for Culture in Stuttgart (Germany).*

*A truly international musician, Ruben performs concerts with the most prestigious orchestras around the world using Fides and Beck instruments exclusively.*

## *Rubén Simeó plays:*

### *Bb-Trumpets:*

*Fides "RS" Symphony Masterpiece Rubén Simeó*

*Fides Symphony Classic*

*Fides Symphony BBG*

*Beck Konzert-Trumpet Opus B LG*

### *C-Trumpets:*

*Fides Symphony Masterpiece Classic*

*Fides Symphony Classic*

### *D/Es/E-Trumpet:*

*Beck Masterpiece*

### *A/B-Piccolo:*

*Fides/Beck Masterpiece*

### *Flugelhorn:*

*Fides/Beck Melisma Masterpiece*

### *Corno da Caccia:*

*Beck Venatio*







# Carlos Martín

*Carlos Martín* Born in Sedaví, Valencia (1979).

*He began studying trombone with the Angel Cariñena and Salvador Tarrasó.*

*His jazz formation initiated in Sedajazz with Francisco Angel Blanco "Latino".*

*Subsequently, he received classes from Michael Philippe Mossman and the prestigious trombonist Conrad Herwig.*

*He has performed with musicians and / or Formations as great as: Mingus Big Band, Carla Bley, Steve Swallow, George Colligan, Jane Lee, Mike P. Mossman, Paolo Freshu, Jonathan Kreisberg, Greg Hopkins, Bebo Valdés, Perico Sambeat, Ramón Cardo, Orquesta de Cambra del Teatre Lliure, Orquesta Simfónica de Córdoba, Chano Dominguez, George Mraz, Big Band do Hot Clube Lisboa, Luis Perdomo, Giovanni Hidalgo, Sedajazz Latin Ensemble, Sedajazz Big Band, Jordy Rossy, Mario Rossy, Marc Miralta, Jesús Santandreu, Skytrain, Eladio Reinón...*

*He has taught at the Taller de Músics de Barcelona (2008 -2012), and ESEM (Escola Superior d'Estudis musicals Taller de Músics) (2010-2012).*

*Since 2012 he is professor of trombone-Jazz at MUSIKENE (Conservatorio Superior de Música del País Vasco).*

*Prize from the "Asociació de Músics de Catalunya" 2003.*

*His debut album "The Journey" has been voted one of the best albums of 2013 by the American-Canadian magazine LatinJazzNet.*

*In other areas of music he has collaborated and/or recorded with artists such as Pablo Alborán, Alejandro Sanz, Alicia Keys, Andrea Bocelli, David Foster, Jorge Drexler, Presuntos Implicados, Niña Pastori...*

## *Carlos Martín plays:*

*Fides Bb-Trumpet Symphony Classic Bb (page 12)*

*Fides/Beck Melisma Bb-Flugelhorn Masterpiece (page 30)*

*Fides/Beck Melisma C-Flugelhorn Masterpiece (page 32)*

*Fides Bb-Trombone Symphony (page 34)*

*Fides/Beck Jazz-Trombone „Marylin“ Masterpiece (page 33)*

# Chen Guang

*Chen Guang, born in China, pursued his studies in Vienna with distinction.*

*He performs as a trumpet soloist with the China National Symphony Orchestra and works as a trumpet soloist with other prestigious orchestras around the world.*

*Chen Guang is a Professor at Beijing's Central Observatory.*

*Photo:  
Chen Gang at the Beijing Conservatory  
with Beck Bb-Trumpet OPUS B Masterpiece*



# András Fejér

*András Fejér From 1987 to 1997 he was the solo trombonist with the Hungarian National Philharmonic Orchestra and in 1995 received the award for Orchestra Artist of the Year.*

*In 1997 he performed as trombone soloist with the Deutsches Symphonie-Orchester Berlin. András is now working as a soloist and as a key member of the orchestra Fides Symphony Closed Wrap.*

*Commenting about our trombone (page 34), András says:*

*"This instrument has a special sound colour...quite dark, very flexible, and can also sound very delicate and soft in the orchestra.*

*The Fides Symphony trombone can be used as a solo instrument in a chamber orchestra, taking advantage of its large, full and centered sound. The tuning is perfect; you do not need particular corrections. The air conduction is very natural and there is no resistance. The reason behind this is not only the new form of the slide but also you can handle the different joints very easily and comfortably.*

*For 10 years I had been looking for a better way to play more freely - and I've finally found it with this trombone."*

*Awards in international competitions:*

- *of the Czech music „Spring of Prague“*
- *1995 First Prize in Toulon (France)*
- *1995 Third Prize in ARD competition in Munich (No first and second prize)*





Fides Bech  
Masterpiece

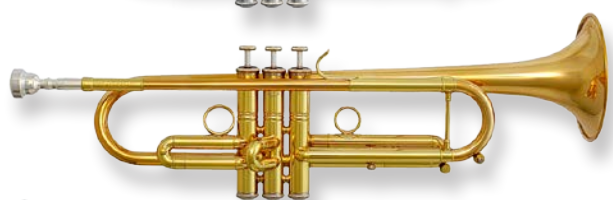
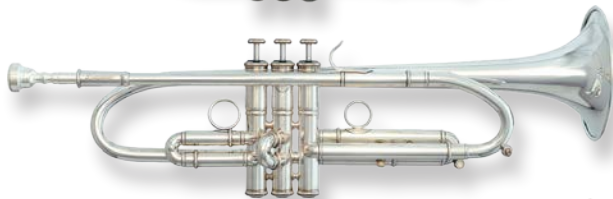
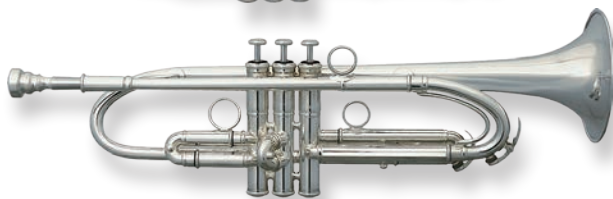
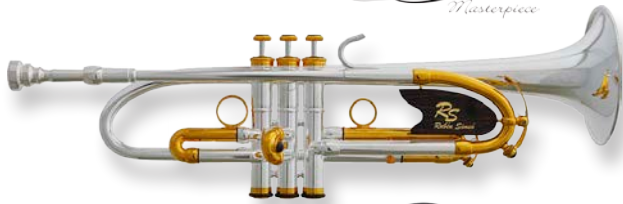

## Bb- Trumpets

### Masterpiece Rubén Simeó

#### „RS“-Custom „Series 9000“

Our top model, this instrument is custom made and has been developed with the young and exceptional trumpeter Ruben

Simeó. It is constructed entirely by hand and features parts of noble wood and goldplated pieces. *Page 7*

### Masterpiece Lead „Series 9000“

A lead trumpet of superior quality.

This is a new concept with a narrower 11.5 mm bore, large bell and new mouthpiece, capable of a very open and high-pitched register with a centered resonance. *Page 8*

### Masterpiece Symphony 44 „Series 9004“

A handcrafted, orchestral trumpet, built with a larger bell (Model 44) and reverse lead pipe. A special feature is that the main slide is built with two reverse tubes.

*Page 9*

### Masterpiece Symphony „Series 9000“

The matriarch of Fides trumpets. Our first and landmark model, created with the idea of making a universal professional trumpet, bringing together sound and ease of use by design. Sound Meets Design - a model that allows you to customize it to your own professional tastes.

*Page 10*

### Symphony Classic „Series 8000“

The classic version of our Symphony series. Constructed with heavier materials than models such as the Standard or Symphony LT trumpets, renowned for their orchestral sound

*Page 11*

### Symphony LT „Series 7000“

The light and basic version of the Symphony Series.

Constructed with light materials to deliver a clearer and brighter sound. *Page 11*

### Jazz I Satin und Jazz II Antik „Series 8900“

Two models built with different materials, one heavy and one light, which by their construction and design in the bell and main slide, make them ideal for trumpeters looking for a characteristic Jazz sound.

*Page 12*

### Vivace „Series 6000“

With a more classic design than the Symphony series, this instrument is aimed at musicians who love a classic sound. Because of its size and construction - and reverse lead pipe - it's ideal for intermediate and advanced students looking for an easy and versatile instrument. *Page 13*

### Pioneer „Series 5000“

The most versatile series of Fides trumpets. Constructed with high quality materials for the lead pipe, main slide and Gold Brass bell, this trumpet is designed for students looking more than just a good sounding trumpet. *Page 14*

### Primera „Series 4000“

For FIDES, the First Series is the most important. We believe it is essential for students to begin their studies with a good instrument. Our efforts are focused on creating instruments of great quality at affordable prices, so that in your early stages of learning you only have to concentrate on studying. *Page 14*

# Fides Beck Masterpiece Rubén Simeó

RS-  
Custom

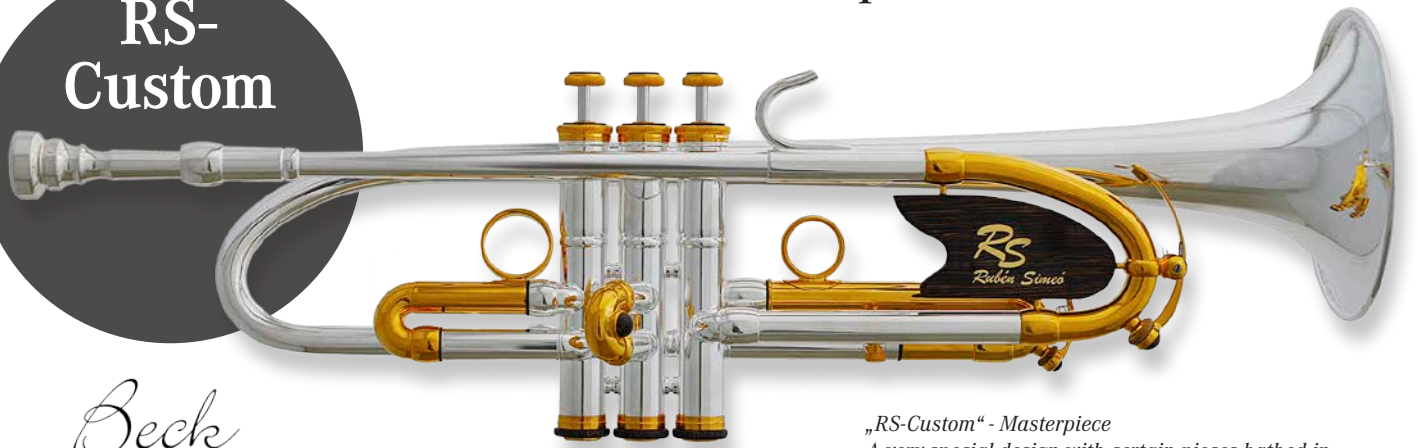

Beck  
Masterpiece

„RS-Custom“ - Masterpiece  
A very special design with certain pieces bathed in gold, a sound sail and ornamentation complemented with noble wood.

Custom models combine traditional craftsmanship with the latest technology to achieve the highest quality. Exceptional musicians deserve exceptional instruments. The exceptional RS model we have developed with - and for - Ruben Simeó, was only achieved through extensive testing and our pursuit of perfection.



## RS-Custom - Rubén Simeó

*New designs for the water key, collars (ferrule) and the insertion - skillfully combined in an elegant form.  
The inclusion of gold parts and small, ornamental pieces of wood make the RS Custom a unique Masterpiece instrument.*

*Series: Custom, Model FTR-9000RS*

*Bore: ML 11,68 mm (0,459"), Valves: Stainless Steel, Leadpipe RS, „Soundsail“ of Precious Wood,  
Handcrafted Design Braces and Mouthpiece Receiver, Bell: BBG Ø 127 mm (5")*

*Weight: ca 1090 (38,45 oz), Leadpipe, Tuning Slide Bow and Bell: Gold Brass  
Outside Slides: Nickel Silver, Design Water Key, Silver Finish, Gold Plated Parts  
Gigbag: Performer*



Fides „Lead“ -  
Beck Masterpiece

Lead



Beck  
Masterpiece



**Brilliant High Register**

Our first model with a bore of 11,5 mm (0,452").  
For this breakthrough specification the Trumpet Lead  
now has a brilliant new sound.  
For a comfortable feeling we developed a new  
leadpipe for the biggest bell in the current Fides  
portfolio.

With the modern and individual design that Matthias  
Beck brings to his instruments, this model has the  
unmistakable character of Fides.



Above: Bending a main slide  
Right: Third slide measurement control  
Below: Solder valve section

**Lead Masterpiece**

Series: Professional Masterpiece, Model FTR-9000LD  
Bore: ML 11,68 mm (0,452")  
Valves: Stainless Steel  
Leadpipe: „Lead“  
Handcrafted Design Braces and Mouthpiece Receiver  
Bell: BBG 127 mm (Ø 5")  
Weight: ca 1100 g (38,8 oz)  
Leadpipe, Tuning Slide Bow and Bell: Gold Brass  
Outside Slides: Nickel Silver  
Design Water Keys  
Finish: Silver Plated  
Gigbag: Performer

Special designs are possible

# *Jides* Symphony Beck Masterpiece Bb 44

44

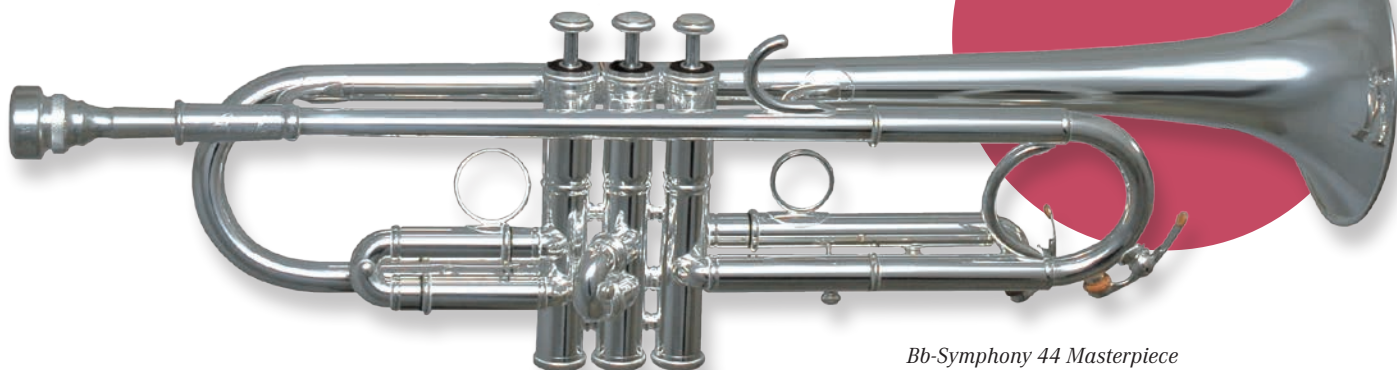

*Bb-Symphony 44 Masterpiece*

## **Bell 44 and Reverse Lead Pipe 44**

The development of the new bell and the corresponding mouthpiece make this trumpet a wonderful instrument, both in size and sonority.

The result of this combination is the Symphony 44, a trumpet for musicians who favour a dark and orchestral sound.

*Beck*  
Masterpiece

### **Bb-Symphony 44 Masterpiece**

*Series: Professional Masterpiece  
Model: FTR-9004ML  
Bore: ML 11,68 mm (0,459")  
Valves: Stainless Steel  
Reversed Leadpipe Model 44  
Handcrafted Design Braces and  
Mouthpiece Receiver  
Bell: 44, Ø 124 mm (4-7/8")  
Weight: ca 1080 g (38,09 oz)  
Leadpipe, Tuning Slide Bow and  
Bell: Gold Brass  
Outside Slides: Nickel Silver  
Design Water Keys  
Finish: Silver Plated or Laquered  
Gigbag: Performer  
Special designs are possible*



*Love the details!*

*Elegant designs for the water key, ferrule and insertions - will never fail to impress and attract attention.*

# Slides Symphony in B Beck Masterpiece

## Our amazing story began with this instrument.

The Symphony Masterpiece was exhibited for the first time at La Namm Show - and what followed surpassed our expectations.

Not only did it draw attention to its design but also - following the comments we received for its quality - it strengthened our belief that we were on the right track.

The oval design combines visual appeal and efficiency, improving the sensation of comfort to the musician and making it an unmistakable instrument.

The Masterpiece model is available in a choice of sizes, finishes and variations.

*Beck*  
Masterpiece

Master  
piece

The title of „Masterpiece“ is a guarantee that the instrument is built in our workshop in Dettingen (Germany) and is completely handmade.

Through the symbiosis of modern technologies and the wisdom of traditional craftsmanship, you are assured that our instruments are built to the most exacting standards to meet the highest demands placed on them. Each part of the instrument is tested meticulously before and during manufacturing to obtain the best result.

### B-Symphony Masterpiece

*Series: Professional Masterpiece*

*Model: FTR-9000*

*Bore: ML 11,68 mm (0,459“) or  
L 11,76 mm (0,462“)*

*Valves: Stainless Steel*

*Leadpipe: Standard*

*Design Mouthpiece Receiver*

*Handcrafted Design Ferulles*

*Bells: Standard Ø 124 mm (4-7/8“) or  
BBG Ø 127 mm (5“)*

*Weight: ca 1090 g (38,45 oz)*

*Leadpipe, Tuning Slide Bow  
and Bell: Gold Brass*

*Outside Slides: Nickel Silver*

*Design Water Keys*

*Finish: Silver Plated or Laquered*

*Gigbag: Performer*

*Special designs are possible*



*B-Symphony Masterpiece,  
Main slide and bell with an  
innovative and contemporary  
design.*



# Fides Bb Symphony - Classic

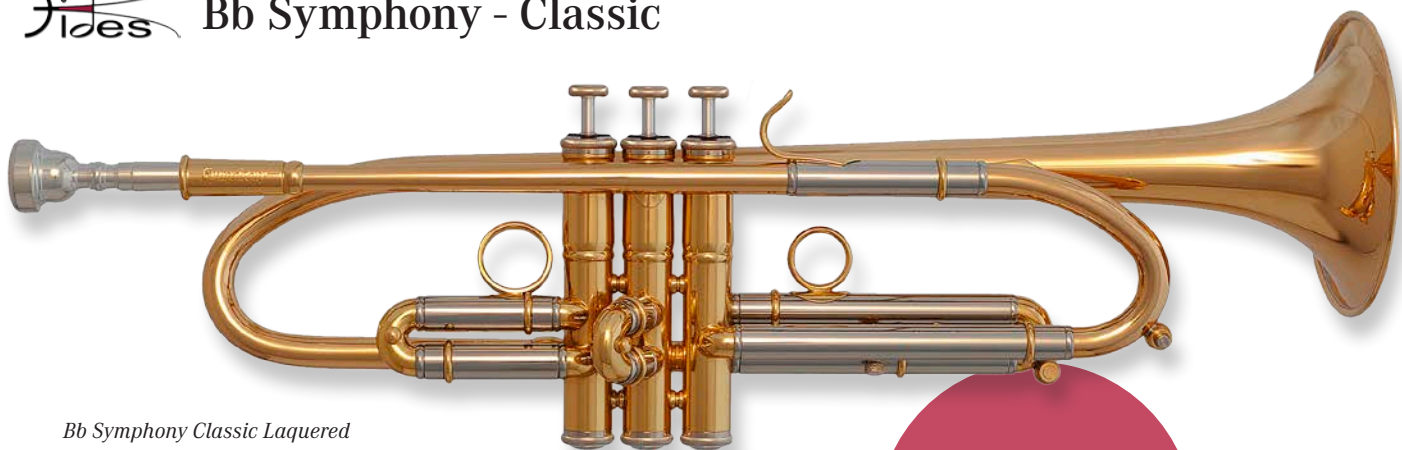

*Bb Symphony Classic Laquered*

## B-Symphony Classic

*Series: Professional*

*Model 8000*

*Bore: ML 11,68 mm (0,459") or  
L 11,76 mm (0,462")*

*Valves: Stainless Steel*

*Leadpipe: Standard heavy*

*Design Mouthpiece Receiver*

*Bells: Standard Ø 124 mm (4-7/8")  
or BBG Ø 127 mm (5")*

*Weight: ca 1170 g (41,27 oz)*

*Leadpipe, Main Slide Bow  
and Bell: Gold Brass*

*Outside Slides: Nickel Silver*

*2 Water Valves*

*Finish: Silver Plated or Laquered*

*Gigbag: Performer*

**Classic**

## Bb Symphony Classic

This model is the descendant of the Masterpiece prototype. Its modern styling, with the characteristic Fides design and ergonomic construction, made for a truly individual series with great depth of character.

Our intention was to create an instrument with excellent sonority and for all the registers (es el termino correcto) to be easily attainable.

The construction of the instrument with a more dense material provides us with a more compact sound.

The design of the receiver and the ferrule is elegant and aesthetically pleasing.

# Fides Bb Symphony LT

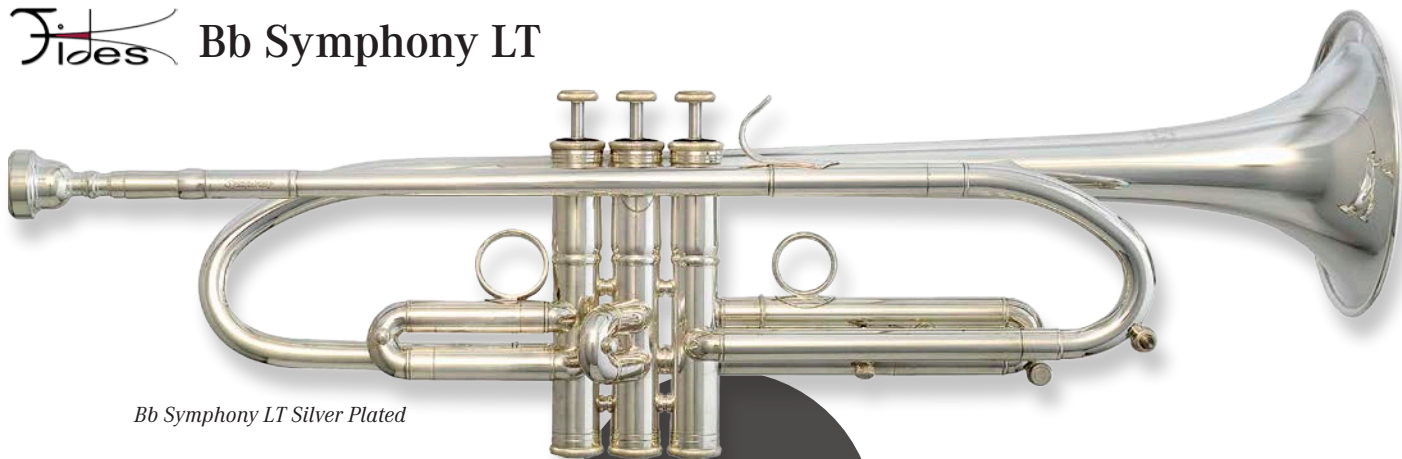

*Bb Symphony LT Silver Plated*

## Bb-Symphony LT

*Series: Professional*

*Model 7000*

*Bore: ML 11,68 mm (0,459") or  
L 11,76 mm (0,462")*

*Valves: Stainless Steel*

*Leadpipe: Standard LT*

*Bells: Standard Ø 124 mm (4-7/8")  
or BBG Ø 127 mm (5")*

*Weight: ca 1020 g (35,98 oz)*

*Leadpipe, Main Slide Bow  
and Bell: Gold Brass*

*Outside Slides: Nickel Silver*

*2 Water Valves*

*Finish: Silver Plated or Laquered*

*Gigbag: Protector*

**LT**

## Bb-Symphony LT

This model from the Symphony series is particularly appealing for its lightweight construction and for its bright and clear performance.

We have achieved a noticeable weight reduction through the use of lighter materials, especially for the lead pipe, receiver and ferrules.

The quality of the material is the same as that of her sister Classic; only it is lighter.

It's an extremely versatile model and is capable of being used for a variety of musical styles. Its value for money only enhances its popularity

## Fides Jazz I Bb - Satin

With the models Jazz I and Jazz II we wanted to create a strong visual presence for Jazz musicians. To achieve this in Jazz 1 we have used Red Brass in the bell and we have treated the surface by sanding it to a spectacular finish.

The choice of this material and design gives us a sweet, dark and big sound.

In the Jazz II we use Yellow Brass with an Antique finish for those looking for a brighter sound.

Choosing the traditional configuration of the tuning slide in combination with our characteristic bell shape results in a quite distinctive sound.

### Jazz II Bb - Antique

*Series: Professional  
Model: FTR-8900MLA  
Bore: ML 11,68 mm (0,459")  
Valves: Stainless Steel  
Main Slide Bow: Traditionell  
Leadpipe: Standard LT  
Mouthpiece Receiver: Jazz  
Bells: Ø 124 mm (4-7/8")  
Weight: ca 1000 g (35,27 oz)  
Leadpipe, Main Slide Bow  
and Bell: Gold Brass  
Outside Slides: Nickel Silver  
2 Water Keys  
Finish: Antik  
Gigbag: Protector*

Fides

## Jazz II Bb - Antique

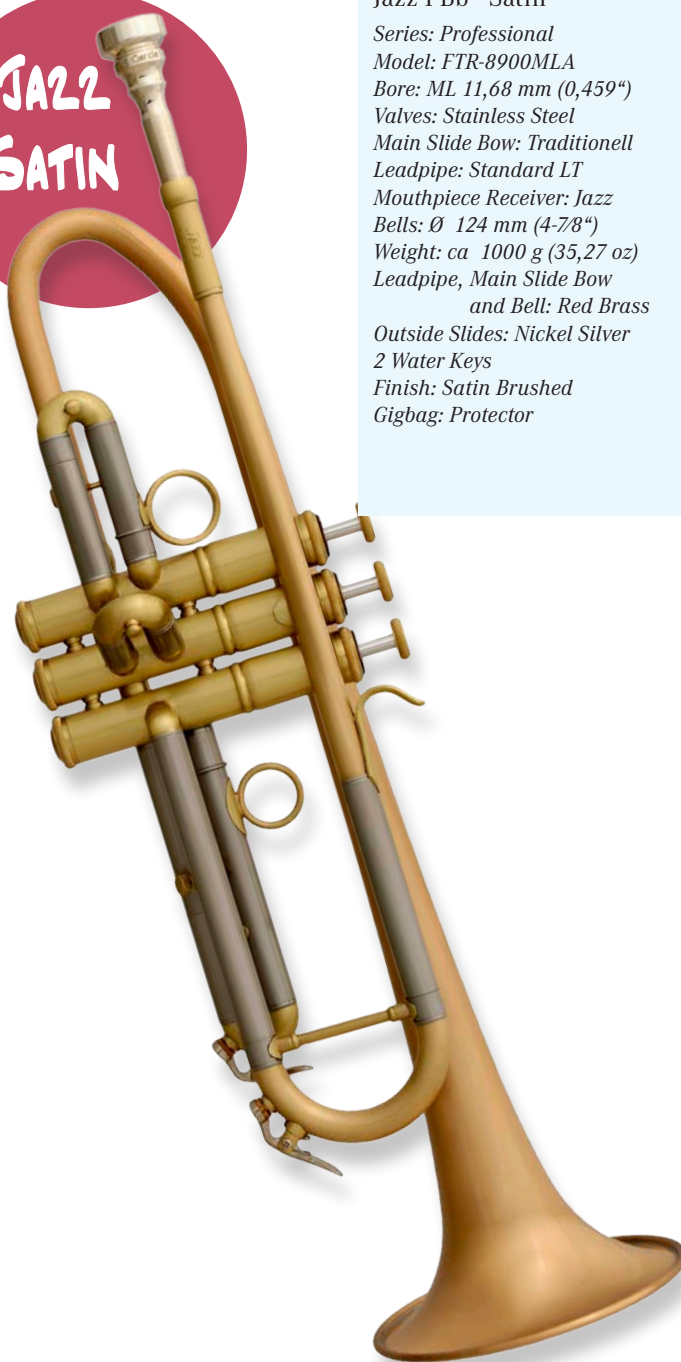

### Jazz I Bb - Satin

*Series: Professional  
Model: FTR-8900MLA  
Bore: ML 11,68 mm (0,459")  
Valves: Stainless Steel  
Main Slide Bow: Traditionell  
Leadpipe: Standard LT  
Mouthpiece Receiver: Jazz  
Bells: Ø 124 mm (4-7/8")  
Weight: ca 1000 g (35,27 oz)  
Leadpipe, Main Slide Bow  
and Bell: Red Brass  
Outside Slides: Nickel Silver  
2 Water Keys  
Finish: Satin Brushed  
Gigbag: Protector*

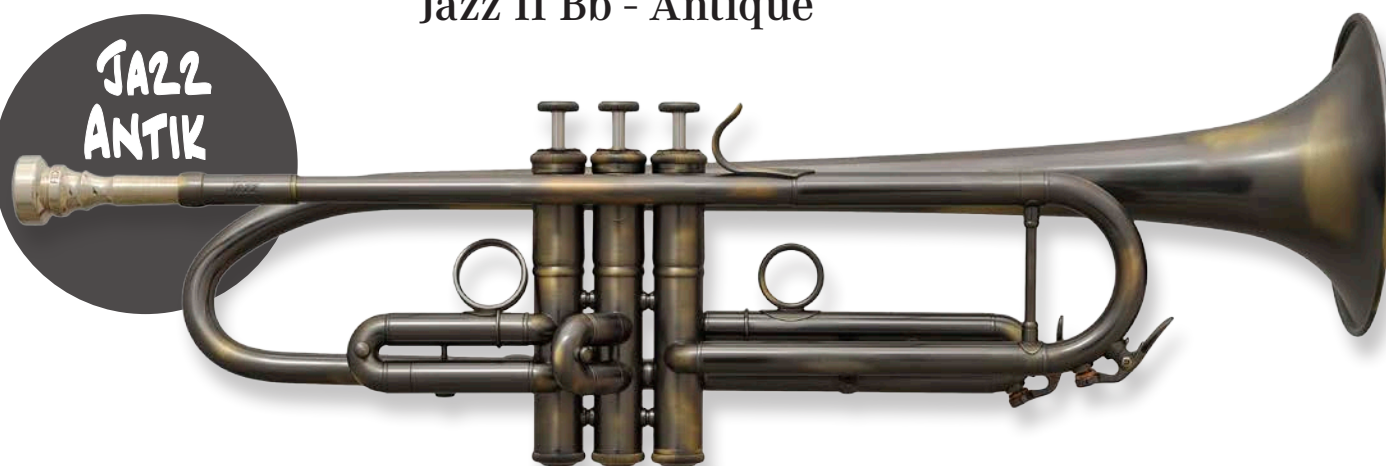

The logo for Fides, featuring the brand name in a stylized, cursive font with a red horizontal line through the middle of the letters.

## „Vivace“ Bb

A detailed photograph of a silver-plated Bb trumpet, shown from a three-quarter perspective. The instrument features a reverse lead pipe, three valves, and a large bell. A red circle with the word "Vivace" in white is overlaid on the upper part of the instrument.

# Vivace

Vivace Bb, our intermediate model

With a more classical design than the Symphony series, it is an instrument aimed at musicians who love a classic sound. Its size and construction, with a reverse lead pipe, a special finger hook, make it ideal for intermediate and advanced students seeking an instrument that's easy to play with a truly impressive sound.

The materials used in its construction include Gold Brass for the mouthpiece, main slide and bell, with Nickel Silver for the tubes. Altogether, the Vivace might be an intermediate instrument but it's crafted with the same care and quality as for professionals.

### Bb-Trumpet Vivace

*Series: Intermediate*

*Model: FTR-6000ML*

*Bore: ML 11,68 mm (0,459")*

*Valves: Stainless Steel*

*Leadpipe: Reversed 44*

*Bell: Standard Ø 124 mm (4-7/8")*

*Weight: ca 1060 g (37,38 oz)*

*Leadpipe, Main Slide Bow  
and Bell: Gold Brass*

*Outside Slides: Nickel Silver*

*Mouthpiece Receiver Vivace*

*2 Water Keys*

*Finish: Silver Plated or Laquered*

*Gigbag: Protector*

*A new elegant receiver with reverse lead pipe in Gold Brass.  
The ring on the first slide and the outer tubes are made of Nickel Silver.*



## Fides Bb Pioneer - Student Model

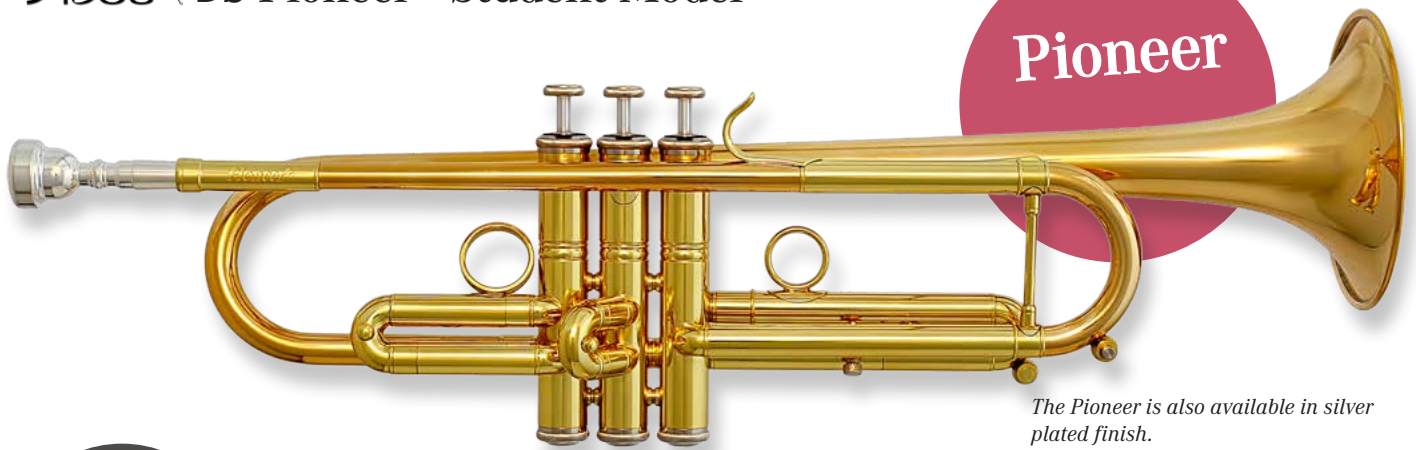

Pioneer

The Pioneer is also available in silver plated finish.

### High-Quality Claim

#### AIMING FOR THE HIGHEST STANDARDS FOR STUDENTS

When you begin learning how to play the trumpet, it's likely that your fingers may not allow the flexibility and strength that you would like. This will come in time. This is why it's important for you to learn on an instrument that makes it easier for you to improve your abilities while you study.

The Pioneer is the most versatile series from Fides. Built with high quality materials and featuring a Gold Brass lead pipe, main slide and bell, this instrument is designed for students looking for more than just a good trumpet.

#### Bb-Trumpet Pioneer

Series: Student  
Model 5000ML  
Bore: ML 11,68 mm (0,459")  
Valves: Stainless Steel  
Leadpipe: Standard Student  
Bell: Standard Ø 124 mm (4-7/8")  
Weight: ca 1015 g (35,80 oz)  
Leadpipe, Main Slide Bow and Bell: Gold Brass  
2 Water Keys  
Finish: Silver Plated or Laquered  
Gigbag: Pioneer

## Fides Bb Primera - The very special first trumpet



1000 Gram Pleasure

The Primera is also available in silver plated finish.

#### Bb-Trumpet Primera

Series: Student  
Model 4000ML  
Bore: ML 11,68 mm (0,459")  
Valves: Stainless Steel  
Leadpipe: Standard Student  
Bell: Standard Ø 124 mm (4-7/8")  
Weight: ca 1000g (35,27 oz)  
Leadpipe: Gold Brass  
2 Water Keys  
Finish: Silver Plated or Laquered  
Gigbag: Primera

The perfect choice for students.

When you're getting started, it's most important that the moving parts work effortlessly, offering an easy response and perfect tuning. At Fides, we believe it is essential that you begin your studies with the right instrument. Therefore, we have put significant effort into creating affordable instruments with great quality so that you only need to concentrate on learning.



*Symphony C-44 Masterpiece*

**C-  
Trumpets**



**Masterpiece Symphony C-44 „Series 9014“**

With a pedigree of timeless craftsmanship, this orchestral trumpet incorporates a larger bell (Model 44) and reverse lead pipe. A special feature is that the main slide is built with two reverse tubes.

*Page 16*



**Masterpiece „Series 9010“**

The matriarch of Fides trumpets. Our first and landmark model, created with the idea of making a universal professional trumpet, bringing together sound and ease of use by design. Sound Meets Design - a model that allows you to customize it to your own professional tastes.

*Page 16*

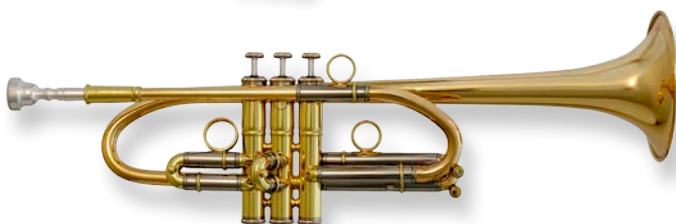

**C-Symphony Classic „Series 8010“**

The classic version of our Symphony Series. Constructed with heavier materials than a Standard or LT model to provide a rich orchestral sound.

*Page 17*



**C-Symphony LT „Series 7010“**

The light and basic version of the Symphony Series. Built with light materials that give a clearer and brighter sound.

*Page 17*



**C-Pioneer „Series 5010“**

The most versatile of the Fides series. Manufactured with high quality materials and featuring a Gold Brass lead pipe, main slide and bell, this instrument is designed for students looking for much more than a good sounding trumpet.

*Page 18*

## Fibes Symphony Beck Masterpiece C-44



*Beck*  
Masterpiece

### Bell 44 and Reverse Lead Pipe 44

The development of the new bell and the corresponding mouthpiece make this trumpet a wonderful instrument, both in size and sonority.

The result of this combination is the Symphony 44, a trumpet for musicians who favour a dark and orchestral sound.

### Symphony C-44 Masterpiece

*Series: Professional Masterpiece*

*Model: FTR-9014ML*

*Bore: ML 11,68 mm (0,459")*

*Valves: Stainless Steel*

*Reversed Leadpipe Model 44*

*Handcrafted Design Braces and Mouthpiece Receiver*

*Bell: 44, Ø 124 mm (4-7/8")*

*Weight: ca 1040 g (36,68 oz)*

*Leadpipe, Tuning Slide Bow and*

*Bell: Gold Brass*

*Outside Slides: Nickel Silver*

*Design Water Keys*

*Finish: Silver Plated or Laquered*

*Gigbag: Performer*

*Special designs are possible*

## Fibes Symphony Beck Masterpiece in C

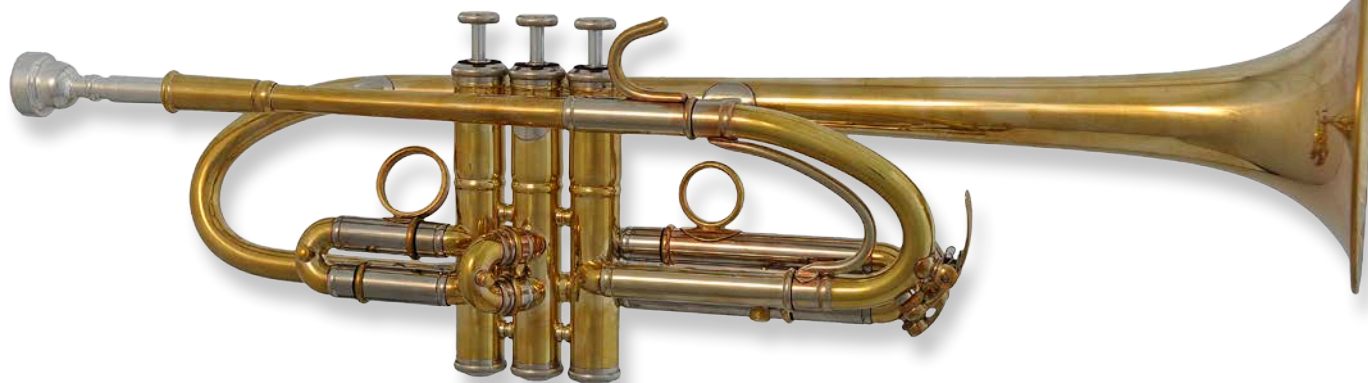

Master  
piece

*B-Symphony Masterpiece unlaquered.  
Main slide and bell with an innovative  
and contemporary design.*

*Beck*  
Masterpiece

The title of „Masterpiece“ is a guarantee that the instrument is built in our workshop in Dettingen (Germany) and is completely handmade.

Through the symbiosis of modern technologies and the wisdom of traditional craftsmanship, you are assured that our instruments are built to the most exacting standards to meet the highest demands placed on them.

Each part of the instrument is tested meticulously before and during manufacturing to obtain the best result.

### C-Symphony Masterpiece

*Series: Professional Masterpiece*

*Model: FTR-9010*

*Bore: ML 11,68 mm (0,459") or*

*L 11,76 mm (0,462")*

*Valves: Stainless Steel*

*Leadpipe: Standard*

*Design Mouthpiece Receiver*

*Handcrafted Design Ferulles*

*Bells: Standard Ø 124 mm (4-7/8")*

*or BBG Ø 127 mm (5")*

*Weight: ca 1070 g (37,74 oz)*

*Leadpipe, Tuning Slide Bow*

*and Bell: Gold Brass*

*Outside Slides: Nickel Silver*

*Design Water Keys*

*Finish: Silver Plated or Laquered*

*Gigbag: Performer*

*Special designs are possible*



## Fides C Symphony Classic

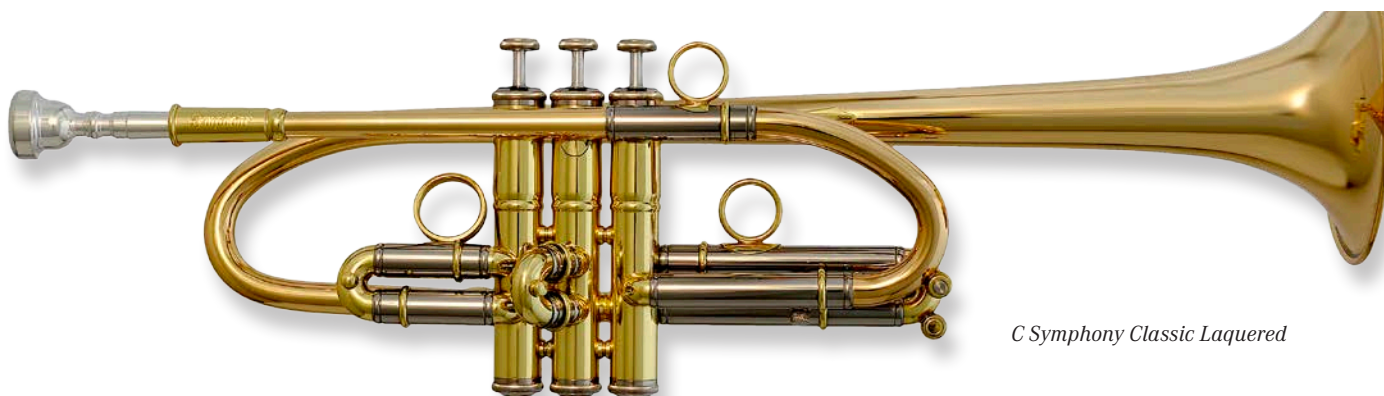

C Symphony Classic Laquered

### C Symphony Classic

This model is the descendant of the Masterpiece prototype. Its modern styling, with the characteristic Fides design and ergonomic construction, made for a truly individual series with great depth of character.

Our intention was to create an instrument with excellent sonority and for all the registers to be easily attainable.

The construction of the instrument with a more dense material provides us with a more compact sound.

The design of the receiver and the ferrule is elegant and aesthetically pleasing.

#### C-Symphony Classic

*Series: Professional  
Model 8010*

*Bore: ML 11,68 mm (0,459") or  
L 11,76 mm (0,462")*

*Valves: Stainless Steel*

*Leadpipe: Standard heavy  
Design Mouthpiece Receiver*

*Bells: Standard Ø 124 mm (4-7/8")  
or BBG Ø 127 mm (5")*

*Weight: ca 1100 g (38,80 oz)*

*Leadpipe, Main Slide Bow  
and Bell: Gold Brass*

*Outside Slides: Nickel Silver  
2 Water Valves*

*Finish: Silver Plated or Laquered  
Gigbag: Performer*

Classic

LT

## Fides C-Symphony LT



C Symphony LT Silver Plated

### C-Symphony LT

*Series: Professional  
Model 7010*

*Bore: ML 11,68 mm (0,459") or  
L 11,76 mm (0,462")*

*Valves: Stainless Steel*

*Leadpipe: Standard LT*

*Bells: Standard Ø 124 mm (4-7/8")  
or BBG Ø 127 mm (5")*

*Weight: ca 980 g (34,56 oz)*

*Leadpipe, Main Slide Bow  
and Bell: Gold Brass*

*Outside Slides: Nickel Silver  
2 Water Valves*

*Finish: Silver Plated or Laquered  
Gigbag: Protector*

### C-Symphony LT

This model from the Symphony series is particularly appealing for its lightweight construction and for its bright and clear performance.

We have achieved a noticeable weight reduction through the use of lighter materials, especially for the lead pipe, receiver and ferrules.

The quality of the material is the same as that of her sister Classic; the LT-model is only lighter.

It's an extremely versatile model and it's capable of being used for a variety of musical styles. Its value for money only enhances its popularity.

Pioneer



High-Quality Claim

AIMING FOR THE HIGHEST STANDARDS FOR STUDENTS

When you begin learning how to play the trumpet, it's likely that your fingers may not allow the flexibility and strength that you would like.

This will come in time. This is why it's important for you to learn on an instrument that makes it easier for you to improve your abilities while you study.

The Pioneer is the most versatile series from Fides. Built with high quality materials and featuring Gold Brass lead pipe, main slide and bell, this instrument is designed for students looking for more than just a good trumpet.

Bb-Trumpet Pioneer

*Series: Student, Model 5010ML*

*Bore: ML 11,68 mm (0,459")*

*Valves: Stainless Steel, Leadpipe: Standard Student*

*Bell: Standard Ø 124 mm (4-7/8")*

*Weight: ca 950 g (33,51 oz), Leadpipe, Main Slide*

*Bow and Bell: Gold Brass, 2 Water Keys*

*Finish: Silver Plated or Laquered*

*Gigbag: Pioneer*

*The Pioneer is also available in silver plated finish.*



# The Cornet

## Fides Bb Cornet Symphony



### Bb-Cornet Symphony

Series: Professional

Model: FCR-7020ML

Bore: ML 11,68 mm (0,459")

Valves: Stainless Steel

Bell: Standard Ø 124 mm (4-7/8")

Weight: ca 1020 g (35,98 oz)

Leadpipe, Main Slide Bow  
and Bell: Gold Brass

Outside Slides: Nickel Silver

2 Water Valves

Finish: Silver Plated or Laquered

Incl. Case

### Bb-Cornet Symphony „Series 7020ML“

Increasingly, we're finding greater demand for music for horns in both symphonic bands and brass bands. We're also aware how soloists are often looking for a sweeter sound. Its modern styling, with the characteristic Fides design and ergonomic construction, made for a truly individual series with great depth of character.

Our intention was to create an instrument with excellent sonority and for all the registers to be easily attainable.

The construction of the instrument with a more dense material provides us with a more compact sound.

## Fides Bb Pioneer Cornet



### Bb-Cornet Pioneer

Series: Student

Model: FCR-5000ML

Bore: ML 11,68 mm (0,459")

Valves: Stainless Steel

Bell: Standard Ø 124 mm (4-7/8")

Weight: ca 970 g (34,22 oz)

Leadpipe and Bell: Gold Brass

2 Water Valves

Finish: Silver Plated or Laquered

Incl. Case

### Bb-Pioneer Cornet „Series 5000“

Increasingly, we're finding greater demand for music for horns in both symphonic bands and brass bands. We're also aware how soloists are often looking for a sweeter sound.

The quality of this instrument exceeds the expectations of a studio series such as the Pioneer.

In fact, you may even be surprised that it is a study series instrument when you try it as the entire Pioneer Series is built with quality tin materials.



# Fides Bb Pocket Trumpets

The  
Small  
„Big One“



## „Big Bell“ Pioneer Bb Pocket Trumpet „Series 5100“

Some teachers have voiced their concerns about the small sonority of pocket trumpets. We have the perfect solution for this. Equipped with a large bell, our pocket trumpet is small in size but delivers a magnificent sound.

### The Two Pockets

*Series: Student, Models: FPT-5000ML and FPT-5100ML*

*Bells: Gold Brass*

*Valves: Stainless Steel*

*Bore: ML 11,68 mm (0,459")*

*Bell Standard: Ø 93 mm (3,66")*

*Big Bell: Ø 122 mm (4,80")*

*Weight Series 5000: ca 890 g (31,39 oz)*

*Weight Series 5100: ca 950 g (33,51 oz)*

*2 Water Valves*

*Finish: Silver Plated or Laquered*

*Incl. Case*

## Pioneer Bb Pocket Trumpet „Series 5000“

The little sister of the Pioneer Big Bell Series. The only difference is the size of the bell, so it has a more direct and brighter sound. With the quality and advantages of the Pioneer Series, this is an ideal trumpet for children and adults looking for a first trumpet, a trumpet for holiday study or just a working trumpet.

The  
Small  
One



*Bb Pocket Laquered*



Masterpiece Piccolotrumpet  
Optional: Screwable parts of precious wood  
Reverse Trigger at the 3rd slide.

Piccolo  
Masterpiece



THE PICCOLO BECK MASTERPIECE Bb/A  
„Series 9090“  
A JEWEL AND AN ABSOLUTE JOY FOR EARS AND EYES.

THE PICCOLO BECK MASTERPIECE Bb / A

After many experiments, measurements, comparisons and assessments of many concerts with different Piccolo trumpets, we have developed this model with great precision. This handmade instrument is deserving the status “Special Edition”.

The new measurement of the bell, together with an 11.5 mm (0,453“) bore results in a pure and open sonority. It has a great response due to the new range of mouthpieces which can be customized to suit your requirements.

The experience of Matthias Beck as a Piccolo concert performer inspired him to design this model to make the musician feel more comfortable while performing.

An ergonomic Finger Hook adds greater comfort while the support ring is designed to be able to move in both length and degrees. You can even disassemble it for a more comfortable handling.

There’s also a novel system to tune the third slide. If you are a trumpeter who normally uses the piccolo you will truly appreciate these enhancements.



Reverse Trigger  
A very easy and comfortable tuning system to make life easier for the musician.  
With the thread of our tuning system you can move the length of the trigger which adds greater levels of security and peace of mind.  
With the option of changing the fourth slide, you can use the fourth slide as well as the first piston.



# Fides Piccolo-Trumpet Bb/A Beck Masterpiece

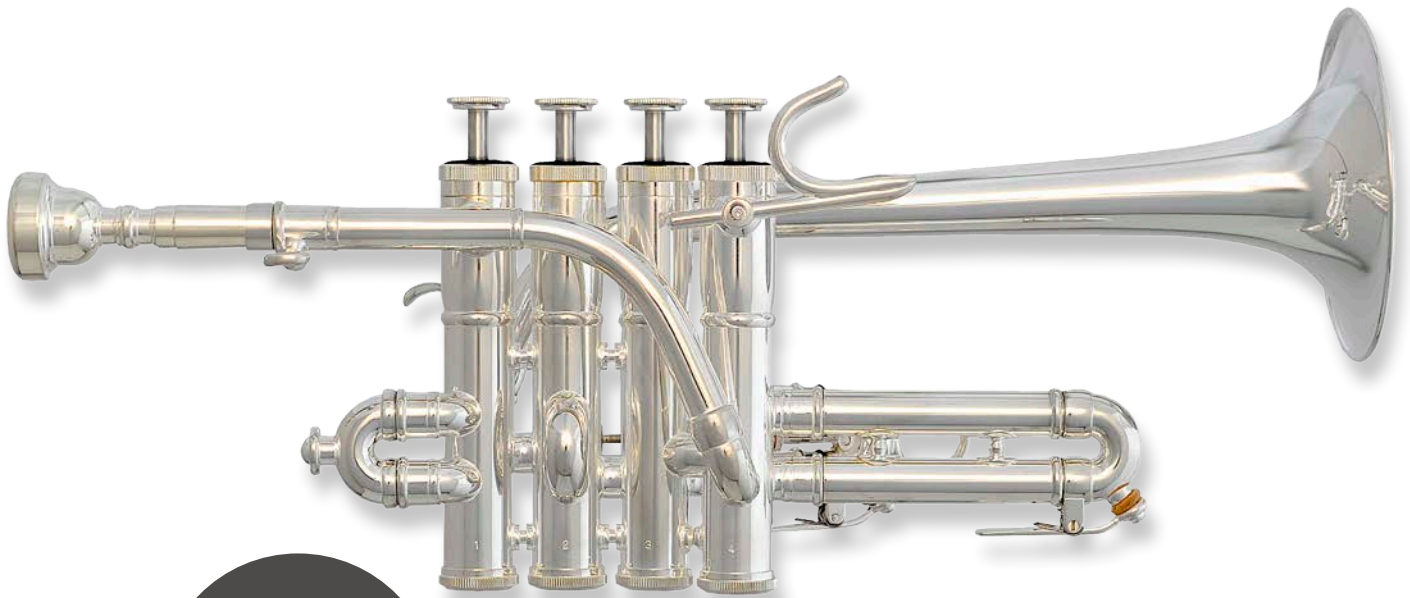

sound  
meets  
design



*During the manufacturing process the tuning and resonance of the instrument is being controlled with bespoke software*



*Assembly without tightness through skilled craftsmanship.*



*Experience and craftsmanship are hallmarks of the Masterpiece series. The inner and outer tubes are made with Nickel Silver*

*The skilled manual assembly results in a quality that surpasses other instruments assembled in this series. Manual cleaning as opposed to chemical cleaning does not damage or remove welding.*



*The ergonomic Finger Hook and outstanding design make our piccolo a most comfortable and pleasant instrument to play.*



**Piccolo Bb/A Masterpiece**  
 Series: Professional Masterpiece  
 Model: FPI-9090  
 Bore: M 11,5 mm (0,453")  
 Valves: Stainless Steel  
 2 Leadpipes (1 Bb, 1 A, Cornet- or Trumpetshank)  
 Masterpiece-Design  
 Adjustable Fingerhook  
 Thumb Hook  
 Bell: Ø 104 mm (4-3/32")  
 Weight: ca 1000 g (35,27 oz)  
 Outside Slides: Nickel Silver  
 Design Water Keys  
 Finish: Silver Plated or Laquered  
 Gigbag: Protector for 2 Trumpets

**Optional:**  
 Reverse Trigger for the 3rd Slide  
 Screwable Parts of precious wood  
 4th Slide chanegable

*Special designs are possible*

# Jipes Bb/A-Symphony Piccolo-Trumpet

## Symphony Bb/A Piccolo „Series 8000“

A professional piccolo at a highly competitive price.

The design of this piccolo descends from our Piccolo Masterpiece.

All parts, from the mouthpiece to the valve section and the bell are new design features.

As a series production we are pleased to offer a very competitive price for this kind of instrument.

It has an easy response that, along with its good tuning and bright sonority, will satisfy the most demanding of trumpeters.

It is offered with four mouthpieces (two for Bb and two for A), a shank for horn and for trumpet - and is supplied with a robust case to complement this exceptional musical instrument.

## Piccolo Symphony

### Piccolo Bb/A Symphony Trumpet

Series: Professional, Model: FPI-8000

Bore: M 11,5 mm (0,453")

Valves: Stainless Steel

4 Leadpipes (2 Bb, 2 A, Cornet- and Trumpetshank)

Masterpiece-Design

Adjustable Fingerhook

Bell: Ø 100 mm (3,94")

Weight: ca 980 g (34,57 oz)

Outside Slides: Nickel Silver

Water Valve

Finish: Silver Plated or Laquered

Incl. Case

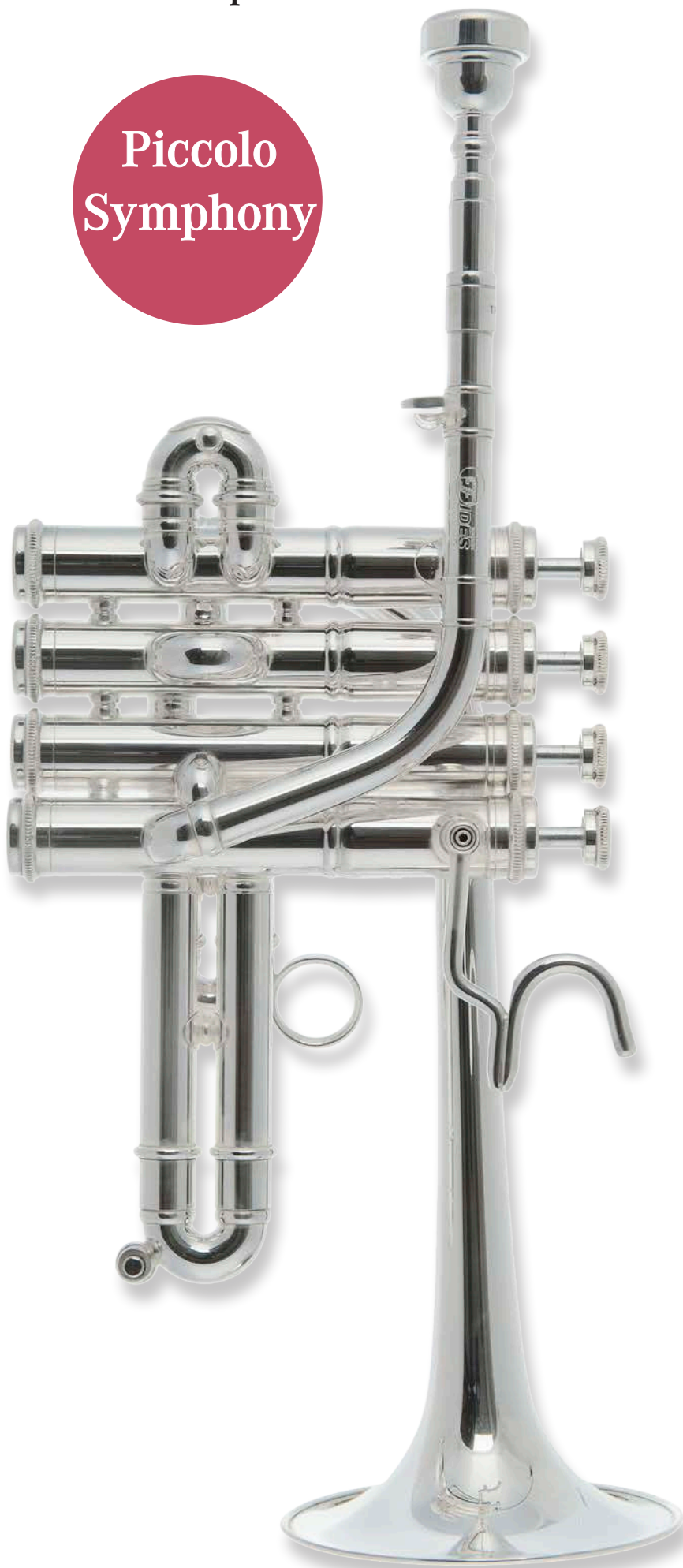

Laquered Version of the Bb/A-Symphony Piccolo (without finger hook, light cups)

**D/Eb/E-Trumpet Beck Masterpiece**

**„Series 9020“**

Our Trumpet Eb / D / E is a truly universal instrument due to its three bells and interchangeable slides.

We have developed the three bells to incorporate different sizes and three sets of slides for perfect tuning across all tones.

This adaptability means, we have three instruments in one, and the interchangeable parts can be purchased separately as required.

With its bore of 11,5 mm (0,453“), unusual in Eb / D / E trumpets, we have also designed a new leadpipe. Together these factors make our trumpet an instrument with a fabulous sound while providing more freedom and expression to the trumpeter.

This instrument is ideal for solo trumpeters and symphonic orchestras.

**D/Eb/E-Trumpet Masterpiece**

*Series: Professional Masterpiece  
Model: FTR-9020, Bore: M 11,5 mm (0,453“)  
Valves: Stainless Steel, Masterpiece-Design  
Adjustable Fingerhook (not shown on the photo)  
Bells: Standard Ø 124 mm (4-7/8“)  
Weight: ca 900 g (31,75 oz)  
Outside Slides: Nickel Silver  
Water Key at the 3rd Slide  
Bell, Leadpipe Bows: Gold Brass  
Finish: Silver Plated or Laquered  
Gigbag: Protector for 2 Trumpets*

*Each Bell and the bows are available separately*

*Special designs are possible*



**The Flexible D/Eb/E-Trumpet**

*D/Eb/E-Masterpiece „Sanded Silver“ with 3 Changeable Bells 9 Bows*





**Masterpiece Flugelhorn Melisma „Sterling Silver Edition“  
„Series 9500“**

This is our top of the range model in which the construction and assembly is second to none. The bell, tuning slide and mouthpiece are all made from Sterling Silver. Key features of the Masterpiece version include the Beck Ergo Trigger located at the top for the third slide, a conical shape for the main tuning slide, a choice of different sizes for the mouthpiece and three ergonomic water keys designed specifically for this flugelhorn. *Page 26*

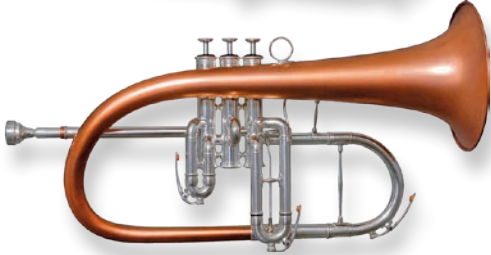

**Masterpiece Flugelhorn Melisma „Cuprum“ „Series 9500“**

A special sound for special musicians! Made with a natural copper bell without lacquer and finished with a special process using glass beads, it has a wonderfully warm, sweet and dark sound. After making the body of the instrument and coated in silver, we weld the natural copper bell. Masterpiece Version (see above). *Page 27*



**Masterpiece Flugelhorn Melisma „Fulgurata“ „Series 9500“**

A very special finish that will fulfill the dreams of many lovers of the flugelhorn. A matt black finish with glittering blue-coloured hues to showcase the brass parts combine to give a heavenly appearance. This is complemented by matt silver finishes for the pumps and other small parts.

The connection between heaven and earth can only be lightning, hence the name “Fulgurata”.

Masterpiece Version (see above). *Page 28*



**Masterpiece Flugelhorn „Melisma“ „Series 9500“**

The Melisma Series represents a true step up in the manufacture of flugelhorns. We have developed many innovative features and over time these have proved to be most welcome. In addition, the craftsmanship behind the manufacture and assembly allows more musicians to fulfill their special desires. Masterpiece Version (see above). *Page 29*



**Flugelhorn „Melisma Professional“ „Series 9000“**

The young (se refiere a algo para jovenes o algo mas nuevo) model, Masterpiece Melisma Professional, completes our line of flugelhorns.

Compared with the flugelhorn of the Masterpiece series, we have replaced the tuning slide with a traditional curve, returning to traditional tuning with the leadpipe.

*Page 30*



**Fides Flugelhorn „Symphony“ „Series 8200“**

This instrument completes the family of the Symphony ranges. Its design keeps the same forms as for both series of trumpets and trombones.

With a Gold Brass bell, Nickel Silver tubes and steel pistons, we guarantee a high quality performance that is worthy of this series.

*Page 31*



**C-Masterpiece Flugelhorn „Melisma“ „Series 9500“**

Here, we have fulfilled Carlos Martín's professional dream.

Masterpiece Version (see above).

*Page 31*



## Outstanding innovation in instrument construction

There are four criteria that take precedence in the manufacture of our flugelhorns.

### Masterpiece Series

1. **Tuning slide**  
We take great pride in the progress we have made in the manufacture of flugelhorns. For example, a tuning system that clearly marks evolution in the manufacture of professional flugelhorns. With the tuning slide, tubes are cylindrical externally and conical in their interior so by design they must be made by hand.  
The benefits of the tuning slide is that you only have to pull the half tuning slide distance in comparison with the „usual leadpipe tuning“, and because of the fixed leadpipe we have continuously the same response and felling, which makes it easier and safer.
2. **Switchable conical leadpipes**  
These give an enhanced response and sound due to the conical nature of their design.
3. **Production procedures with consistent quality control**  
The entire production process is constantly controlled, both acoustically and mechanically.
4. **Sound meets design**  
The total solution of sound, intonation and design is our passion.

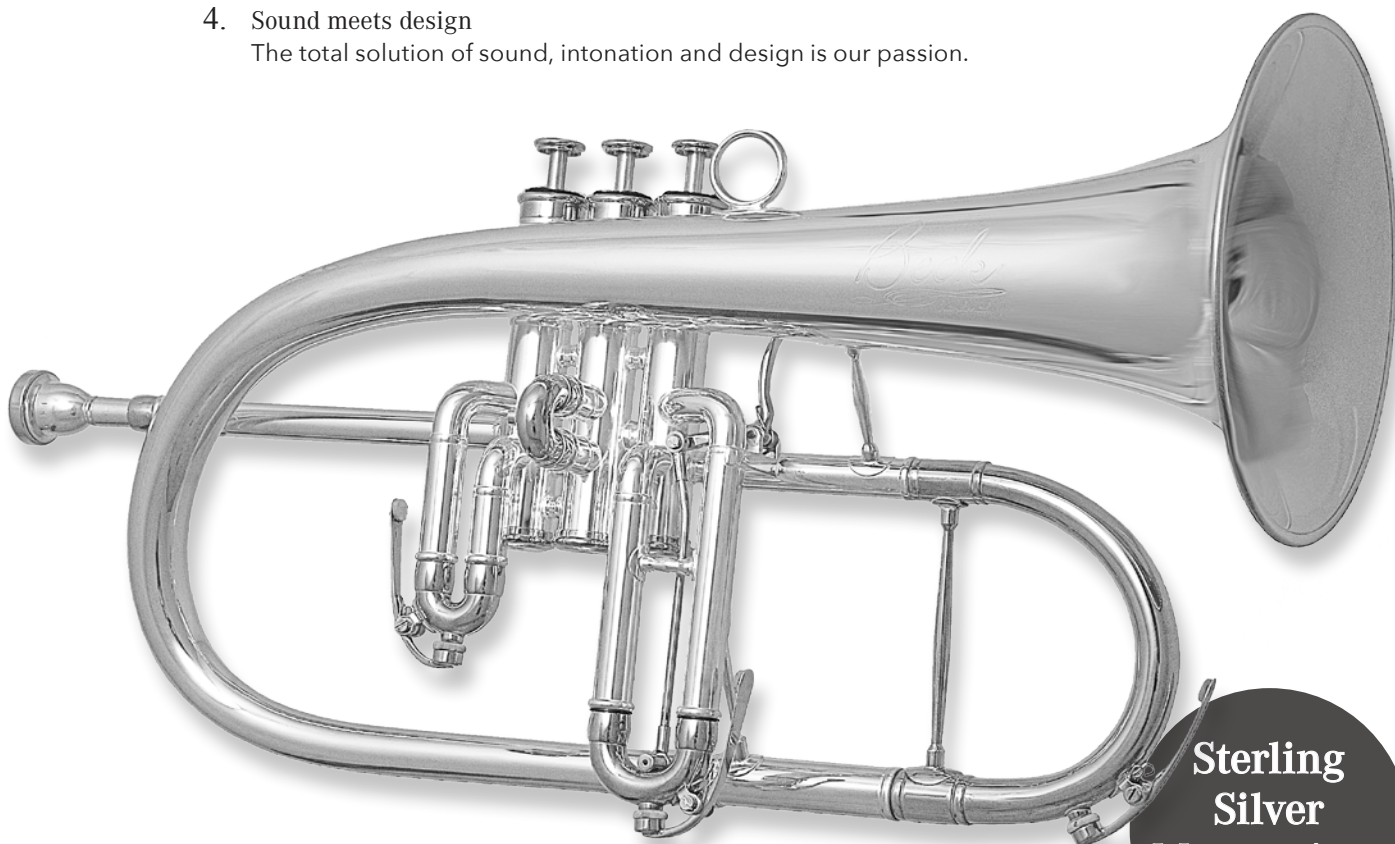

**Sterling Silver Masterpiece**

**Bb Flugelhorn Melisma Masterpiece „Sterling Silver Edition“**

*Series: Professional Masterpiece*

*Model: FFH-9500STS*

*Leadpipe, Tuning Slide Bow and*

*Bell: Sterling Silver*

*Bore: ML 11,0 mm (0,433")*

*Valves: Stainless Steel*

*Changeable Leadpipe*

*Overhead Beck Ergonomic Trigger (3rd slide)*

*Main Tuning Slide, Interior Conical*

*Bell: Ø 160 mm (6,3")*

*Weight: ca 1400 g (49,38 oz)*

*Outside Slides: Nickel Silver*

*3 Design Water Keys*

*Finish: Silver Plated or Laquered*

*Gigbag: Flugelhorn Performer*

*Special designs are possible*

### „Sterling Silver Edition“

This is our top of the range model in which the construction and assembly is second to none.

The bell, tuning slide and mouthpiece are all made from Sterling Silver.

The specific weight is 20% more than brass so the vibration sound waves are less than (Young's model Joven o nuevo otravez) which gives it a unique, darker and earthy sound.

This model is also available in the Rotary Valves version.

The specifications and more details of this series can be found in the following pages.

# Fides Melisma „Cuprum“ Beck Masterpiece Flugelhorn

„Cuprum“  
Masterpiece

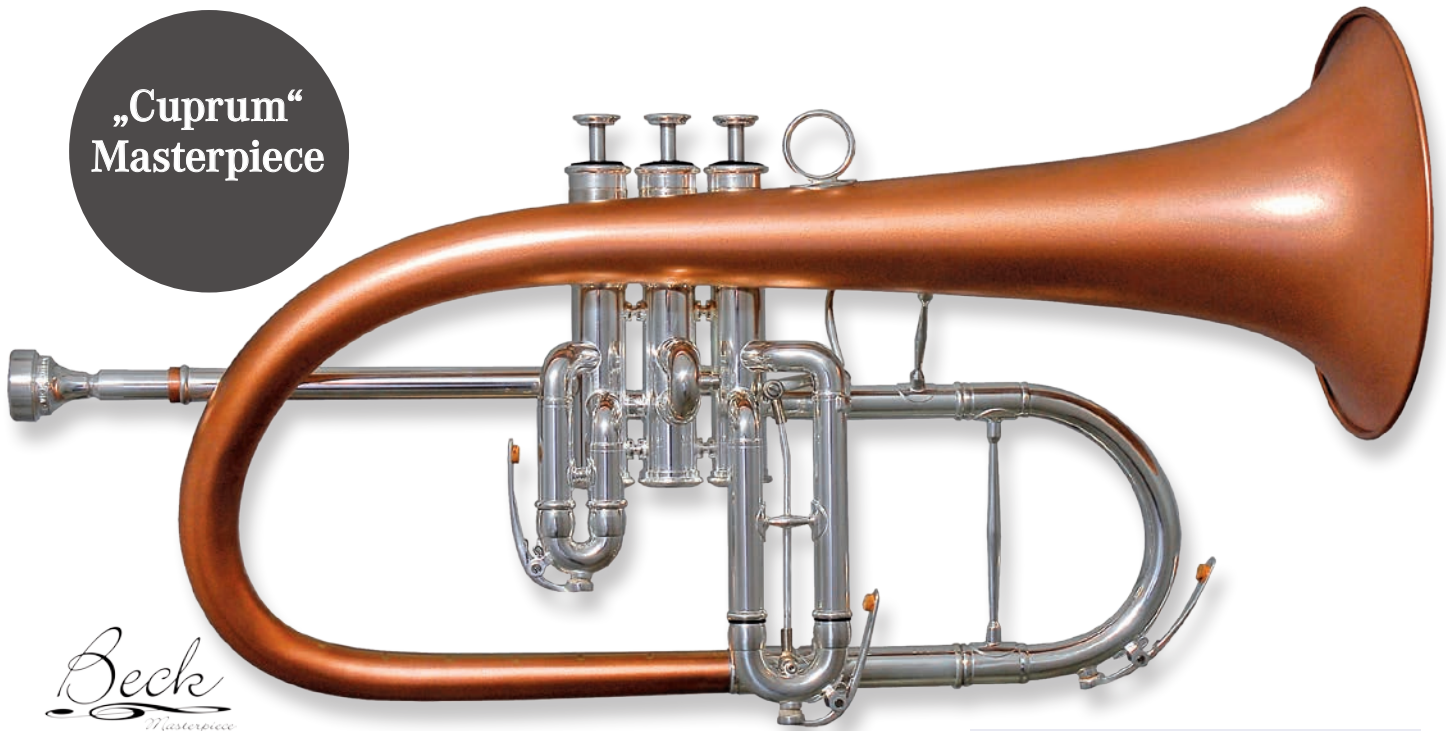

## Our top of the range model with the „Copper“ sound.

A special sound for special musicians! Made with a natural copper bell without lacquer and finished with a special process using glass beads, it has a wonderfully warm, sweet and dark sound.

This instrument epitomizes the quality of our craftsmanship and manufacturing processes.

After making the body of the instrument and coating it with silver, we weld the natural copper bell.

The thickness of the copper bell is 0.6 mm – and this is what produces such a unique sound.

Key features of the Masterpiece version include the Beck Ergo Trigger located at the top for the third slide, a conical shape for the main tuning slide, a choice of different sizes for the mouthpiece and three ergonomic water keys designed specifically for this flugelhorn.

Bb Flugelhorn Melisma „Cuprum“

Series: Professional Masterpiece

Model: FFH-9500CUP

Tuning Slide Bow: Goldbrass

Bell: Copper

Bore: ML 11,0 mm (0,433")

Valves: Stainless Steel

Changeable Leadpipe

Overhead Beck Ergonomic Trigger (3rd slide)

Main Tuning Slide, Interior Conical

Bell: Ø 160 mm (6,3")

Weight: ca 1250 g (44,09 oz)

Outside Slides: Nickel Silver

3 Design Water Keys

Body Finish: Silver Plated

Bell Finish: Sanded Raw

Gigbag: Flugelhorn Performer

Special designs are possible

## Computer Analysis

### Analysis of target tuning with computer

Melisma Masterpiece in comparison with a traditionell made (without tuning slide) Flugelhorn .

The difference of natural tones to the ideal line „0“ is much lower in the Melisma flugelhorn than the professional standard. The top lines are the tuning of natural tones.

The lines below are the same,, but with the slide removed and tuned.

Melisma Masterpiece

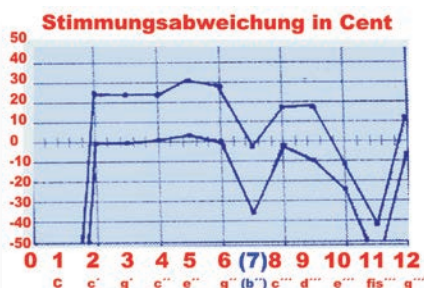

Flugelhorn „Standard“

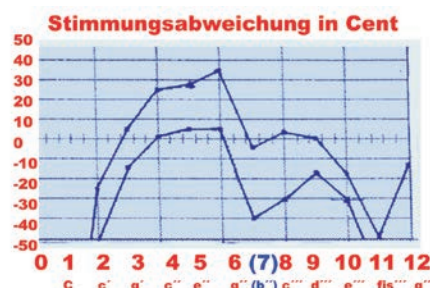

It is clearly visible that the tone No. 7 is always very low on all instruments. This tone is played with Piston No. 1.

The result of the Computer Analysis has been decisive in building a flugelhorn with a slide that improves the pitch.



# Fides Melisma „Fulgurata“ Beck Masterpiece Flugelhorn

FULGURATA  
„thunder  
struck“

Beck  
Masterpiece



## „Fulgurata“ Masterpiece Flugelhorn

A very special finish that will fulfill the dreams of many flugelhorn lovers.

A matte black finish with glittering blue-coloured hues to showcase the brass parts combine to give a heavenly appearance. This is complemented by matt silver finishes for the pumps and other small parts.

The connection between Earth and sky can only be lightning, hence the name “flugurata”.

Bb Flugelhorn Melisma „Fulgurata“

Series: Professional Masterpiece

Model: FFH-9500FUL

Bell and Tuning Slide Bow: Goldbrass

Bore: ML 11,0 mm (0,433“)

Valves: Stainless Steel, Changeable Leadpipe

Overhead Beck Ergonomic Trigger (3rd slide)

Main Tuning Slide, Interior Conical

Bell: Ø 160 mm (6,3“)

Weight: ca 1200 g (42,33 oz)

Outside Slides: Nickel Silver

3 Design Water Keys

Body and Bell Finish: Antik Raw

Slide Bows and Water Keys Sanded, Silver

Plated

Gigbag: Flugelhorn Performer

Special designs are possible



„Melisma“  
more than just a Flugelhorn

A selection from our big range of  
Beck Melisma-Meisterinstrumente.



# Fides Melisma Beck Masterpiece Flugelhorn



Melisma Masterpiece here in a special finish:  
Silver & Gold Plated

*Beck*  
Masterpiece

Bb Flugelhorn Melisma Masterpiece  
Series: Professional Masterpiece  
Model: FFH-9500MMP  
Bell and Tuning Slide Bow: Goldbrass  
Bore: ML 11,0 mm (0,433")  
Valves: Stainless Steel, Changeable Leadpipe  
Overhead Beck Ergonomic Trigger (3rd slide)  
Main Tuning Slide, Interior Conical  
Bell: Ø 160 mm (6,3")  
Weight: ca 1200 g (42,33 oz)  
Outside Slides: Nickel Silver  
3 Design Water Keys  
Finish: Laquered or Silver Plated  
Gigbag: Flugelhorn Performer  
Special designs are possible

Melisma  
Masterpiece



The Melisma Masterpiece gold plated,  
with tuning slides, water keys and caps finished in matt silver.

# Fides Melisma Beck „Professional“ Flugelhorn

Melisma  
Professional



## Melisma Professional

A traditionally manufactured flugelhorn embodying the measurements and shapes of the Melisma Masterpiece models.

Comparing it to the flugelhorn of the Masterpiece series, we have replaced the tuning slide with a traditional curve, returning to traditional tuning with the leadpipe.

Through a more simplified method of construction we have reduced the weight of the instrument resulting in a greater degree of comfort for the musician.

Individual options are also possible as this instrument is handmade.

## Bb Flugelhorn Melisma Professional

*Series: Professional  
Model: FFH-9000PRO  
Bohrung: 11,0 mm  
Bore: ML 11,0 mm (0,433")  
Valves: Stainless Steel  
Changeable Leadpipe  
Overhead Beck Ergonomic Trigger (3rd slide)  
Bell: Ø 160 mm (6,3")  
Weight: ca 1100 g (38,80 oz)  
Bell and Body: Gold Brass  
Outside Slides: Nickel Silver  
3 Water Valves  
Finish: Laquered or Silver Plated  
Without Case*

*Special designs are possible*



*Detail of a tuning lead pipe*

*Right:  
Photo detail of the Beck Ergonomic Trigger*



*Beck  
Masterpiece*



## Fides Symphony Flgelhorn in B

Symphony

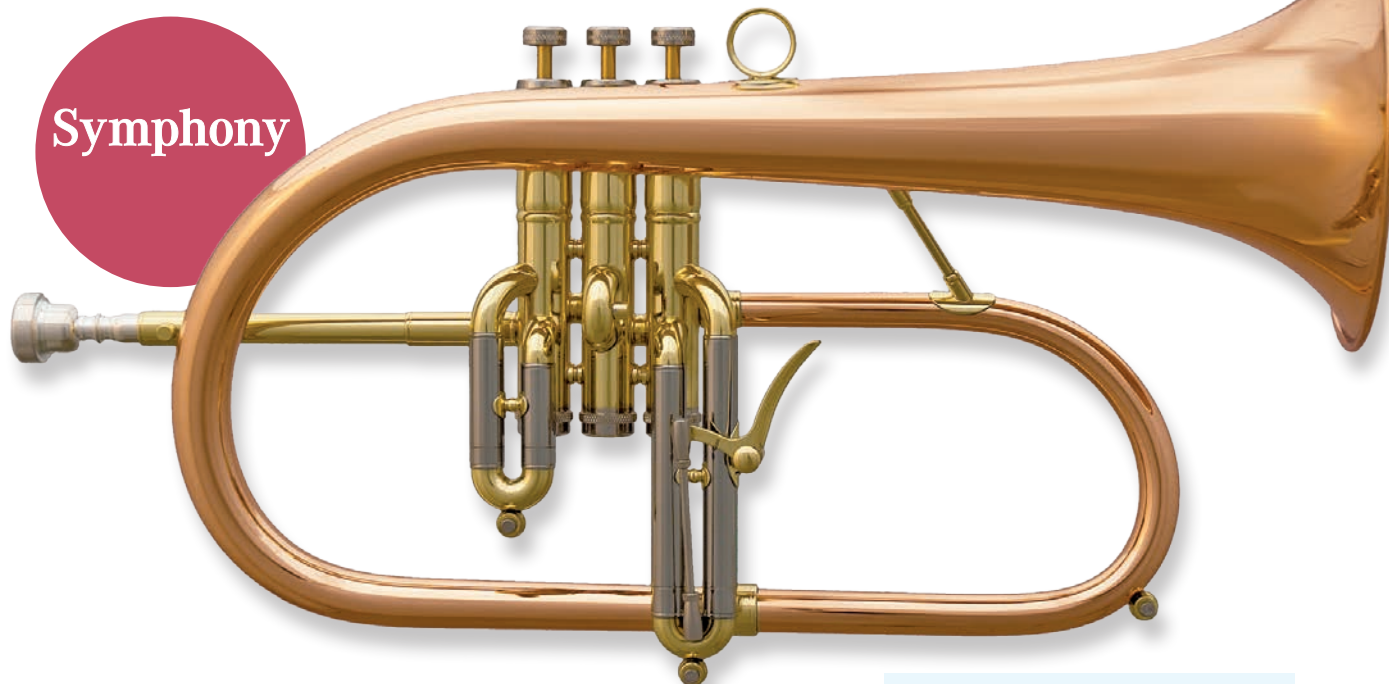

Completing the family of the Symphony range, this design incorporates the same attributes from the whole series of both trumpets and trombones.

With a Gold Brass bell, Nickel Silver tubes and steel pistons, we guarantee a high quality production and performance that is worthy of this series.

### Bb Symphony Flugelhorn

*Series: Professional, Model: FFH-8200*

*Bore: ML 11,0 mm (0,433")*

*Valves: Stainless Steel*

*Bell: Ø 153 mm (6,02")*

*Weight: ca 1150 g (40,56 oz)*

*Outside Slides: Nickel Silver*

*Bell and Body: Gold Brass*

*3 Water Valves*

*Finish: Laquered or Silver Plated*

*Trigger at the 3rd slide*

*Incl. Gigbag*

## Fides Melisma Beck Masterpiece C-Flügelhorn

Masterpiece  
in C



### C Flugelhorn

Melisma Masterpiece

*Series: Professional Masterpiece*

*Model: FFC-9500*

*Bell and Tuning Slide Bow:*

*Goldbrass*

*Bore: ML 11,0 mm (0,433")*

*Valves: Stainless Steel*

*Bell: Ø 145 mm (5,7")*

*Changeable Leadpipe*

*Overhead Beck Ergonomic*

*Trigger (3rd slide)*

*Main Tuning Slide, Interior*

*Conical*

*Weight: ca 1100 g (38,8 oz)*

*Outside Slides: Nickel Silver*

*3 Design Water Keys*

*Finish: Laquered or Silver Plated*

*Gigbag: Flugelhorn Performer*

*Special designs are possible  
(as shown in the photo)*

Here, we have fulfilled Carlos Martín's professional dream.



# Fides Jazz Bb-Trombone „Marylin“ *Beck* Masterpiece



This is Fides' special initiative and our offering to trombonists who love jazz. With the help and guidance of Carlos Martín we have developed a trombone that is easy to use and play, offers great versatility and delivers superb sonority. In short, it is Fides's solution for those who are looking for a pure jazz sound.

Photo:  
Carlos Martín the „Musikhaus Beck“ testing the „Marylin“.

Bb Jazz-Trombone  
„Marylin“  
Series: Professional Masterpiece  
Model: FSL-9000  
Small Shank  
Changeable Leadpipe  
Dual Bore Nickel Silver Slide:  
12,2 mm/12,4 mm (0.480/0.488)  
Brass Bell: Ø 185 mm (7,283")  
Weight: ca 1260 g (44,45 oz)  
Finish. Laquered  
Gigbag

Optional:  
Special designs are possible  
(as shown in the photo)  
Bell: Different diameters  
and materials

MARYLIN

Matthias Beck together with Carlos Martín in the workshop of the „Musikhaus Beck“ developing leadpipes.



# Fides Symphony Bb- & Bb/F-Trombones

Fides Symphony trombones offer high quality and comfort with excellent value for money.

The Symphony is available without a rotary system in Bb and with a rotary system in Bb / F.

On the Bb / F models it is available in the both the Open Wrap and Closed Wrap versions. A version with interchangeable leadpipes is also optional.



*András Fejér, a solo trombonist from the Deutsches Symphonie-Orchester Berlin, performs as soloist and orchestral with the Symphony Closed Wrap.*

*On Page 6 you can see what he has written about our trombone.*



*Carlos Martín is an international jazz trombonist and Professor at the Musikene Conservatory (Higher School of Music) of San Sebastian in Spain.*



Symphony

## Bb/F-Trombone Symphony

*Series: Professional  
Model: FSL-7505  
Big Shank  
Bore: 13,9 mm (0.547")  
Brass Bell: Ø 215 mm (8,46")  
Weight: 1700 g (59,97 oz)  
Valve Section: Open/Closed Wrap  
Nickel Silver Slide  
Gigbag*

*Optional:  
Model Bb (without valve)  
Model with changeable Leadpipes*



## Pioneer Trombone

The Bb Trombone from the Pioneer family is particularly significant for being a light, comfortable and easy to use instrument that is ideal for students.

### Bb-Trombone Pioneer

*Series: Student  
Model: FSL-5000  
Small Shank  
Bore: 12,7 mm (0.50")  
Brass Bell: Ø 202 mm (7,95")  
Weight: 1300 g (45,86 oz)  
Nickel Silver Slide  
Balancer at the tuning slide  
Gigbag*



Pioneer





Rotary Trumpets from the master craftsmen's workshop Beck



arts  
and  
craft

### CRAFTSMANSHIP AND THE LOVE FOR ATTENTION TO DETAIL

The appearance of our instruments is just as important for us as their functionality and performance. It's all part of our philosophy. That's why we go just that little bit further with that extra care when creating the custom designs to be handcrafted with beautiful ornamentation.

sound meets design







Bb-Trumpets

# Rotary Valves

# Trumpets



**OPUS B Masterpiece „Series 9500“**

**Rotary Valve Concert Trompete in ML and L**

A concert trumpet with a great choice of models including two different types of Valve Sections (Meinlschmidt and Zirnbauer) and also two different bores. Finishing according to request.

Page 36 + 37



**OPUS B Professional „Series 9000“**

**Rotary Valve Concert Trompete in ML and L**

A basic but professional concert trumpet. The mouthpiece, bell and valve section are identical to the Masterpiece model. We've only removed trim details. Finishing according to request.

Page 36 + 37



**Opus B & C Masterpiece with Srewable Bells „Series 9500“**

The same as the Masterpiece model but with variations of sonority resulting from the change of different bells in different materials, measures, forms and thicknesses

Page 38

## C-Trumpets



**OPUS C Masterpiece „Series 9500“**

**Rotary Valve Concert Trompete in ML and L**

A concert trumpet with a great choice of models including two different types of Valve Sections (Meinlschmidt and Zirnbauer) and also two different bores. Finishing according to request.

Page 36



**OPUS C Professional „Series 9000“**

**Rotary Valve Concert Trompete in ML and L**

A basic but professional concert trumpet. The mouthpiece, bell and valve section are identical to the Masterpiece model. We've only removed trim details. Finishing according to request.

Page 37

## Piccolotrompete-Hoch B/A



**Piccolo Bb/A Trumpet „Exsultare“ „Series 9500“**

A piccolo with a very intense and focused sonority. The measurement of the bell is a little bigger compared to the usual piccolos. The bore is 10.5 mm (0,413“). For improved ergonomics, we have developed a new wooden support that is both flexible and adjustable.

Page 39

# Beck Trumpets OPUS B and OPUS C Masterpiece

## New OPUS Series

With more than 30 years of experience and extensive testing with orchestras and soloists, we have taken our German trumpets to new levels. The German trumpeter, Eberhard Höflinger has played a key role in our development work.

Here's what he had to say to us:

"Hi Matthias and the Beck team. After having played your trumpets (Opus B1 and Opus C1 Masterpiece) in the orchestra for more than one year, I just wanted to say thank you very much for making these instruments so good.

The tuning is fantastic, the sound always open, powerful and modulable. I play with these models the complete repertoire, starting with symphonic, opera to movie music.

Another great thanks to you and your team."

Eberhard Höflinger  
trumpet soloist of Vogtland Philharmonie



OPUS C Masterpiece silver plated  
Beck-Trigger

Opus C  
Masterpiece

## A wide variety of model variant

*Bb- and C-Trumpets*

*Series: Professional Masterpiece*

*Model: BTR-9500*

*Bores: ML/11,0 mm (0,433") or L/11,2 mm (0,441")*

*Valve Section: Meinschmidt or Zirnbauer*

*Weight C/Bb: ca. 1000 g (35,27 oz)/1040 g (36,68 oz)*

*Bell and Slide Bows: Gold Brass*

*Slides: Nickel Silver*

*Bell Cup thick-walled*

*Beck-Trigger at the 3rd slide*

*Design Ferrules*

*Screwable Leadpipe*

*Handforged Water Key*

*Optional:*

*Various conical leadpipes*

*3rd slide in double slide version*

*Handforged braces*

*Overblowing Keys*

*Pitchfinder*

*Bell and main slide bow in different materials*

*Special designs are possible*



*Optional:*

*3rd slide in double slide version*



*OPUS B Masterpiece silver plated*

## Opus B Masterpiece

*Beck*  
*Masterpiece*

## Bb & C Trumpets Professional

A basic but professional concert trumpet. The mouthpiece, bell and valve section are identical to the Masterpiece model. We've only removed trim details. Finishing according to request.

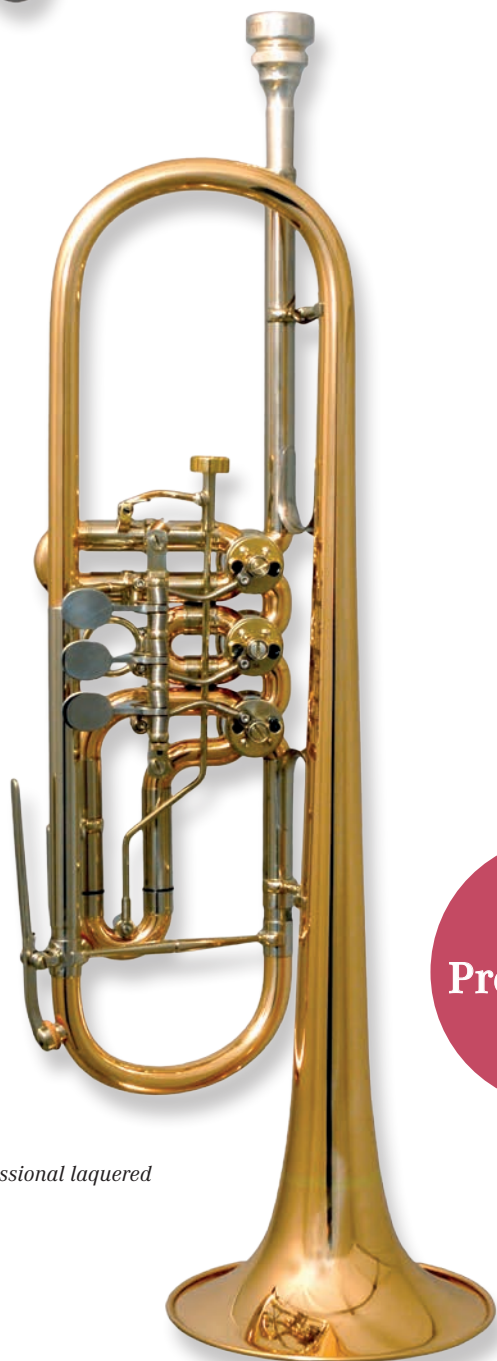

*OPUS B Professional laquered*

## Opus B Professional

### Beck OPUS B & C Professional

*Bb- and C-Trumpets*  
*Series: Professional*  
*Model: BTR-9000*  
*Weight Bb: ca. 1000 g (35,27 oz)*  
*Weight C: ca. 1040 g (36,68 oz)*  
*Valve Section: Zirnbauer*  
*Bell and Slide Bows: Gold Brass*  
*Slides: Nickel Silver*  
*Bell Cup thick-walled*  
*Beck-Trigger at the 3rd slide*  
*Leadpipe Model 35*  
*Beck-Trigger at the 3rd slide*  
*Finish: Laquered or Silver Plated*

*Special designs are possible*





Sound  
Diversity

### Sound Modification

*Identical to the Masterpiece model but with variations of sonority created by the change of bells. Only one part of the bell is removable, the rest is welded compactly.*

*Due to the fact that the bells are made by different materials, shapes and thicknesses means it influences the changes in the sonority that can be achieved.*

*The materials used are Brass, Gold Brass, Nickel Silver, Copper and Sterling Silver, with different restraints and diameters.*

*Beck* Bb/A Piccolo „Exsultare“  
*Masterpiece*

„Exsultare“  
Die Piccolo



**B/A Piccolo Trumpet  
„Exsultare“ „Series 9500“**

*Serie: Professional Masterpiece*

*Model: BPI-9500*

*Bore: 10.5 mm (0,413")*

*Weight: ca 920 g (32,45 oz)*

*Bell and Slide Bows: Gold Brass*

*Thumb Rest Adjustable*

*Slides: Nickel Silver*

*Bell Ø 105 mm (4,13")*

*Beck-Trigger at the 3rd slide*

*Design Ferrules*

*Trumpet Shank*

*2 Leadpipes (Bb and A)*

*Finish: Laquered or Silver Plated*

*Optional:*

*Special designs are possible*



### Venatio

This has been completely adapted to align with contemporary tastes. New moulds have been created along with revisions to the measurements. The result is a highly tuned instrument with exceptional sound.

With the optional leadpipe you can also play this instrument in A. When you want to play in F you will need to change the body completely.

### Venatio Corno da Caccia



In the Baroque period there were different natural instruments of the horn (pablara tecnica) family. We know this from Baroque literature and texts – and from musicians who have played these instruments.

Though our innovation, we have modified some of the measurements, resulting in a much shorter trunk with four valves.

And, with a much larger bell the sonority differs from the sound of a flugelhorn. It can be used with a flugelhorn nozzle and there are also optional trumpet mouthpieces. For high passages we offer a smaller bell.

This instrument has been specially designed for baroque music and with soloists in mind. For example: The concert of Neruda, for ensemble music (que es musica ensemble) and also for band music.

#### Corno da Caccia in Bb „Venatio“

*Series: Professional Masterpiece*

*Model: BCC-9500*

*Bore: 11,5 mm (0,453")*

*Changeable Bell Cup: Ø 230 mm (9,06")*

*Weight: ca 1400 g (49,38 oz)*

*Body, Tuning Slide Bows and Bell: Gold Brass*

*Slides: Nickel Silver*

*German Flugelhorn Shank (Trumpet Shank)*

#### *Optional:*

*Leadpipe for A-Tuning*

*Leadpipe in Bb for French Horn Mouthpiece*

*Body for F-Tuning*

*Water Keys*

*Small Bell*

*Special designs are possible*





innovation  
sound  
design

Meisterwerkstatt des Musikhaus Beck e.K.  
Metzinger Straße 49  
D 72581 Dettingen an der Erms  
[www.musikbeck.de](http://www.musikbeck.de)  
[info@musikbeck.de](mailto:info@musikbeck.de)  
+49 7123 972 775

